

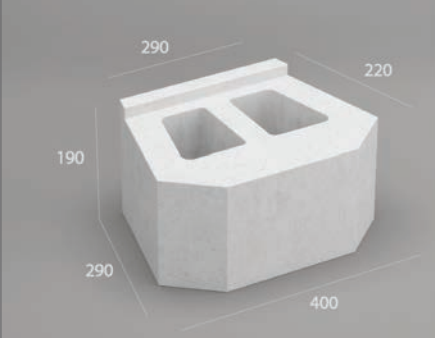

Retaining Wall System - Omega Stone

Omega 2-S
± 31.0 kg

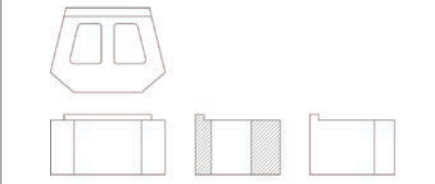

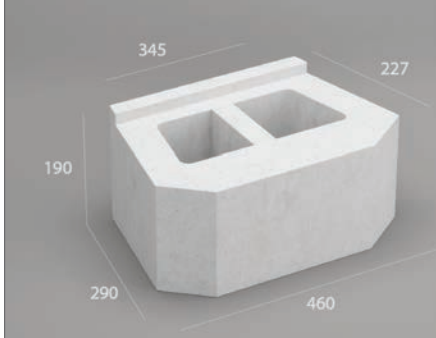
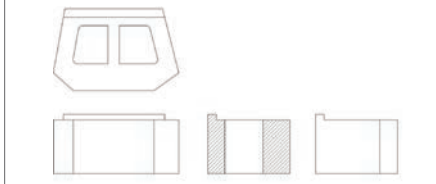

Omega 2-L
± 35.0 kg





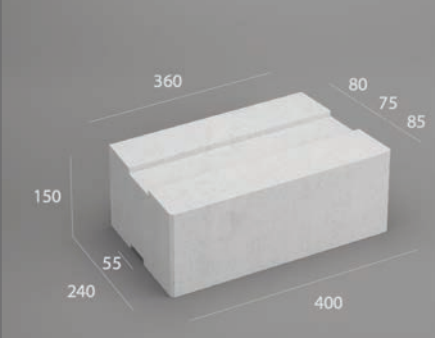
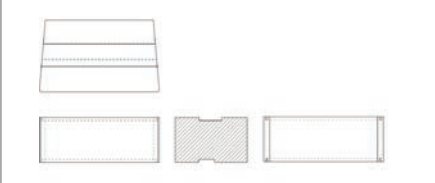

Retaining Wall System - T BLOCK

T-BLK INSERT
± 28.0 kg

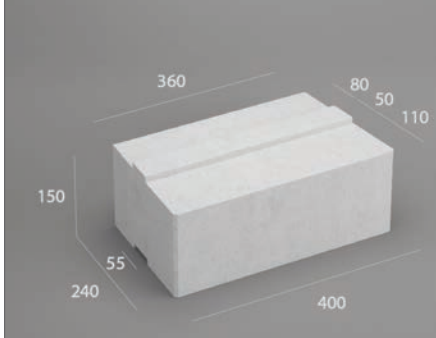
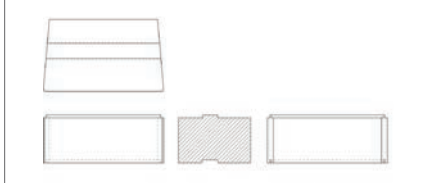
T-BLK RIB
± 25.0 kg

Concrete
Paver



Omega Stone



Retaining Wall - T Block

Project References



P102, P103



P861, P862, P863



P01, P02, P03



P21, P332

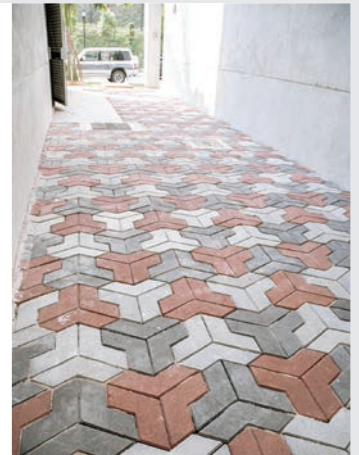

P861, P862, P863



CB 05



GT 01



P311, P312, P313



PPS01



CB 05, P121, P123



CB 05



P101, P102