



SENGDEK®

YOUR ROOFING SOLUTION



SENGDEK®

**YOUR
ROOFING
SOLUTION**

FACTORY ADDRESS

SJ CLASSIC INDUSTRIES SDN. BHD. (434775-H)
Kg Parit Ju, Mk 4, Simpang Kiri, 83050 Batu Pahat, Johor

Telephone Number

07- 418 8888
07- 418 8889
07- 418 8880
07- 418 5852
07- 418 5853

Fax Number

07- 418 5854
07- 418 6333

Website

sengdek.com

Email

enquiry@sjclassic.com

**SENGDEK
CLIP LOCK 730**

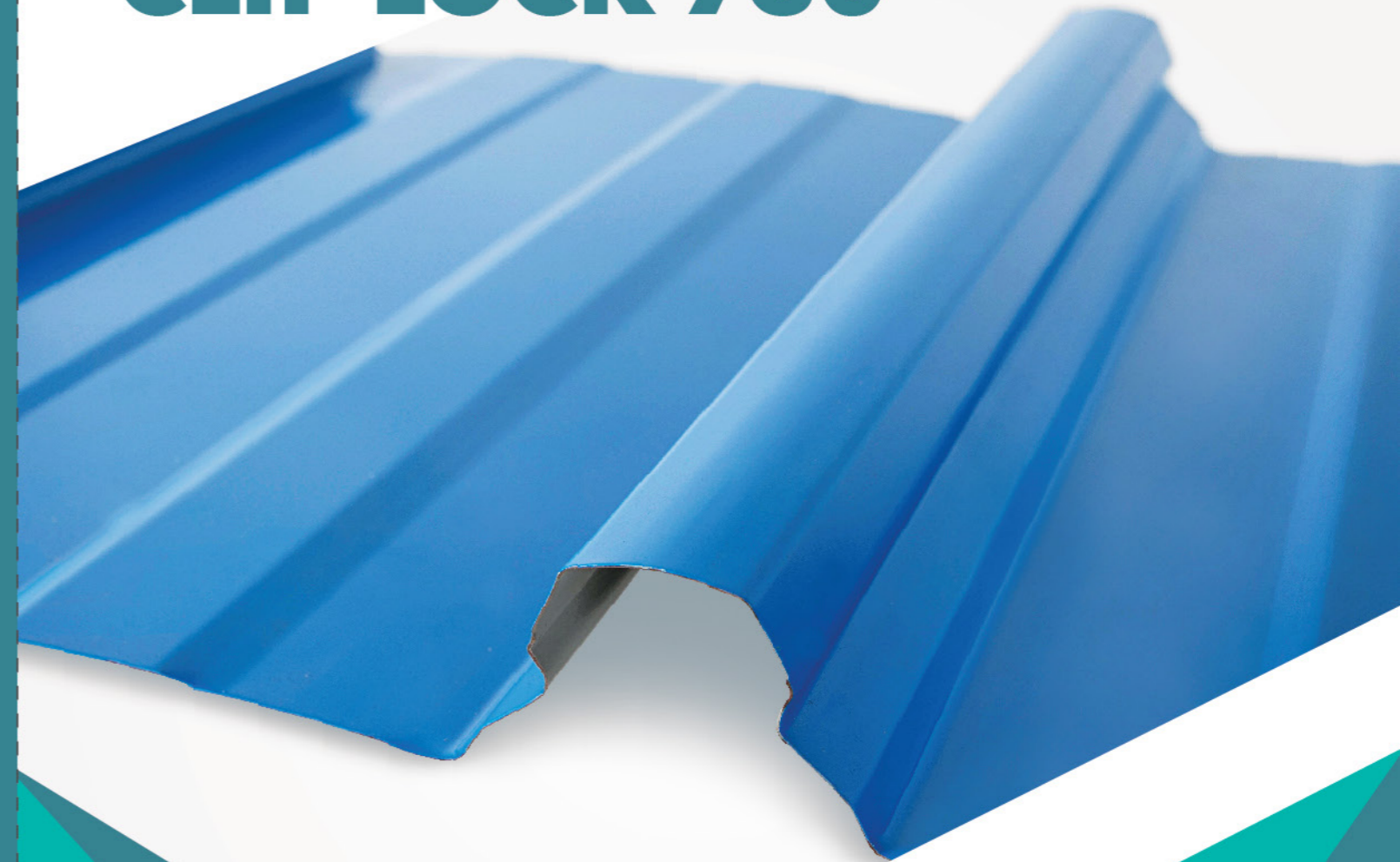

SENGDEK
SINCE
1997

SENGDEK CLIP LOCK 730

SENGDEK Clip Lock 730 is engineered and designed to have interlock action ribs for positive concealed clip fixing. It is only made from the highest quality of high tensile G550 steel coil. **SENGDEK Clip Lock 730** is available in Primero, Thermoshield, and Supreme.

SENGDEK Clip Lock 730 exclusive design makes it well suited for roofs with minimum one degree roof pitch. It provides lightweight but extremely strong water proof system with 240mm fluted pans and 37mm high ribs. **SENGDEK Clip Lock 730** disperses rainwater quickly and efficiently to the outer perimeters of the roof, thus making it an excellent choice for areas with severe rain fall intensity in Asia. **SENGDEK Clip Lock 730** remains as one of the most trusted and reliable products since the past few decades.

SENGDEK Clip Lock 730 is a perfect choice of metal roofing for those building structures that have very low slopes and long spanning roofs. **SENGDEK Clip Lock 730** is also suitable for vertical wall cladding, making it to fulfill industrial needs. This product type is very common in building types such as exhibition hall, warehouse, factory, and shop lot. **SENGDEK Clip Lock 730** is also available in site-forming, mostly for extremely long roofing project.

PROFILE: SENGDEK CLIP LOCK 730

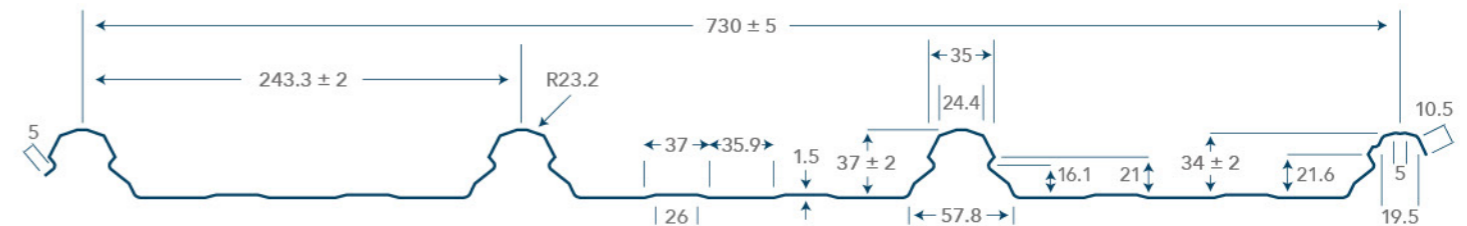
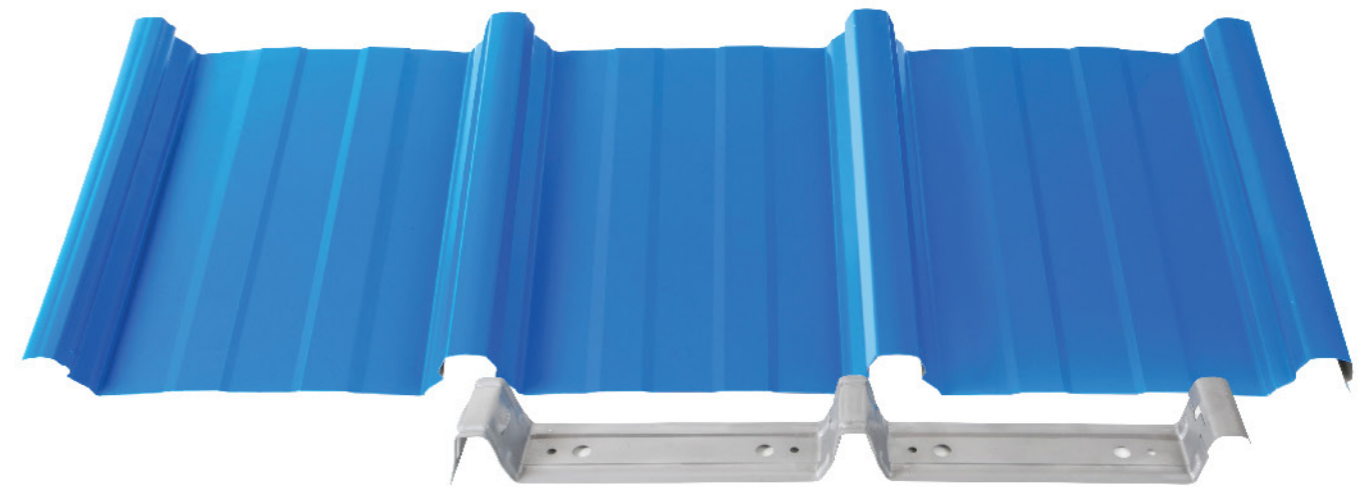

- Combines with smart fluted spans and a lock-action rib design.
- Manufactured from a guarantee high tensile steel substrate protected with corrosion inhibitive treatment.
- Wider effective cover width first in Malaysia of 730mm and rib heights of 37mm.
- For minimum roof pitch of 1.
- Concealed fixing method with clip and locking system.
- Strongly recommend for applications from low pitched roofs to vertical or horizontal ribbed walling for warehouse, shop offices, exhibition halls, modern bungalow and etc.

THICKNESS AVAILABLE

BASE METAL THICKNESS (mm)	TOTAL COATED THICKNESS (mm)	WEIGHT PER METER (kg/m)	WEIGHT PER SQ METER (kg/m ²)	COVERAGE PER TON (m ² /MT)	STEEL GRADE	MIN. YIELD STRENGTH (MPa)
0.35	0.40	2.67	3.77	265	ASTM A446-E	550
0.42	0.48	3.18	4.48	223	ASTM A446-E	550
0.48	0.55	3.61	5.08	197	ASTM A446-E	550

Base metal thickness (BMT) available are 0.35mm, 0.42mm & 0.48mm. Other thickness is upon request & available.

DATA SHEET

MINIMUM FALL

The amount of water that must be shed increases with the length of the roof. To avoid possible back-up of water in severe wind conditions, the following recommended roof length should be considered as maximum for a given roof pitch and rain fall rate.

RECOMMENDED MAXIMUM ROOF LENGTH (M)						
SLOPE IN DEGREE	1°	2°	3°	5°	7.5°	
RAINFALL (mm/h)						
250	130	168	198	245	290	
300	110	142	165	200	247	
400	85	99	120	155	185	
500	67	85	100	124	148	

DISTRIBUTED LOAD CAPACITY - CONTINUOUS SPAN CONDITION

THICKNESS (mm) (TCT)	SPAN	mm	SPAN (mm)								
			900	1050	1200	1350	1500	1650	1800	1950	2100
0.48	Serviceability	kPa	3.07	2.50	2.10	1.55	1.16	0.88	0.66	0.51	0.38
	Strength	kPa	4.90	4.11	3.61	2.93	2.32	1.88	1.56	1.30	1.04
0.55	Serviceability	kPa	4.25	3.37	2.56	1.86	1.29	0.93	0.67	0.58	0.51
	Strength	kPa	6.31	5.22	4.23	3.38	2.75	2.20	1.81	1.62	1.44

MAXIMUM RECOMMENDED SPACING OF SUPPORTS

THICKNESS (mm) (TCT)	ROOF			WALL			MAX ROOF OVERHAND UNSUPPORTED
	SINGLE SPAN (mm)	END SPAN (mm)	INTERNAL SPAN (mm)	SINGLE SPAN (mm)	END SPAN (mm)	INTERNAL SPAN (mm)	
0.48	1600	1700	2200	2400	3000	3600	250
0.55	2000	2300	2800	2700	3300	3900	300

Note: - The roof overhang is not meant for human traffic. All thickness are nominal and provisional. Tolerance may occur and they are subjected to change and variations in accordance to finished product's condition.

SAMPLE OF SPECIFICATION

0.48mm TCT (Thickness) SENGDEK Clip Lock 730 Roofing Sheets to be fixed onto SENGDEK Clip in Pre-painted zinc-coated steel or aluminium-zinc coated steel. And come complete with necessary fittings and accessories. Details in accordance with manufacturer's instructions.

FIXING CLIP

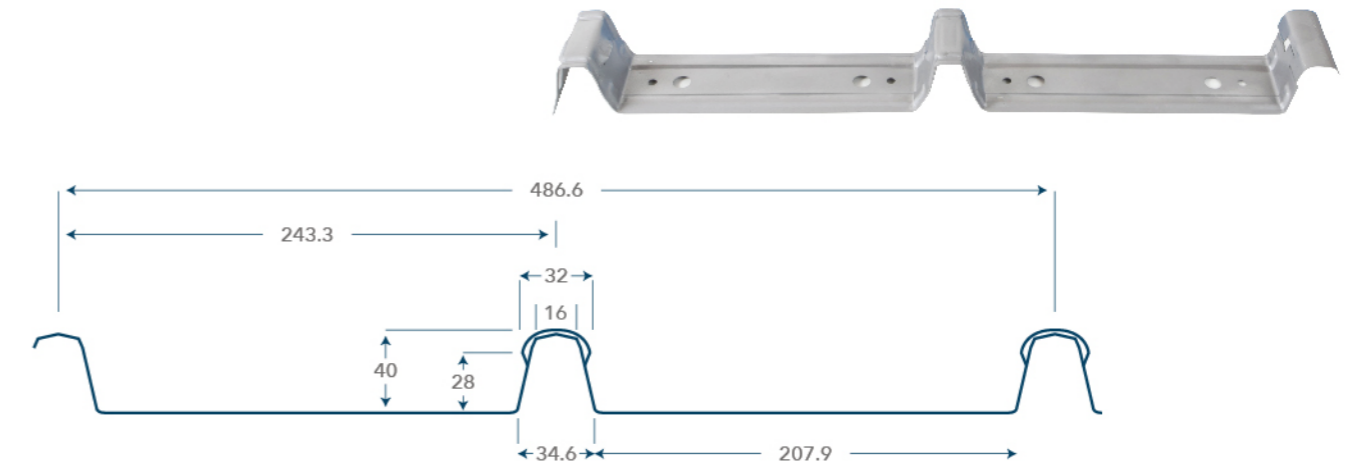

FIXING TO STEEL SUPPORTS

THICKNESS (mm)	NO INSULATION (Directly to supports)	OVER INSULATION BLANKET
UP TO 4.5mm	No.10 - 12 x 25mm water head self-drilling steel screws	Increase to 22mm long screw if required
EXCEED 4.5mm	No.10 - 24 x 32mm water head self-drilling steel screws	

FIXING TO TIMBER SUPPORTS

THICKNESS (mm)	NO INSULATION (Directly to supports)	OVER INSULATION BLANKET
HARDWOOD	No.10 - 12 x 25mm water head self-drilling steel screws	Increase to 45mm long screw if required
SOFTWOOD	No.10 - 12 x 45mm water head self-drilling steel screws	

* RECOMMEND 4 SCREW PER FIXING CLIP

STANDARD ACCESSORIES

STANDARD FLASHING / CAPPING

RIDGE CAPPING SC12

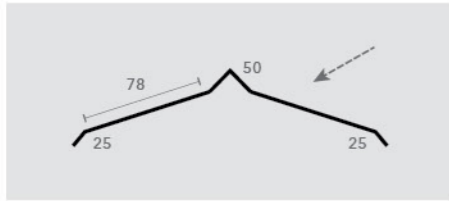

RIDGE CAPPING SC18

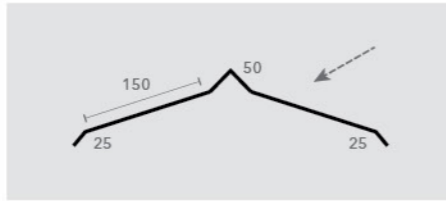

RIDGE CAPPING SC24

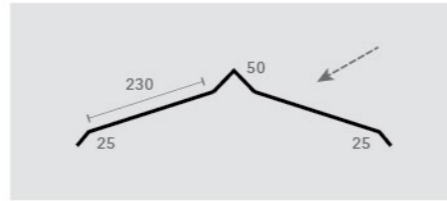

V CAPPING SC12

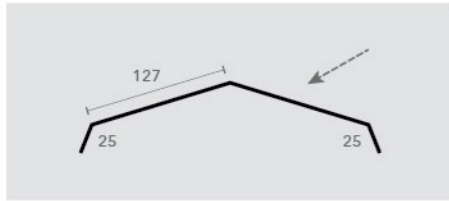

V CAPPING SC18

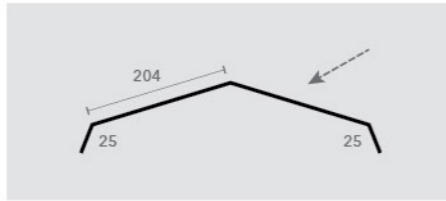

V CAPPING SC24

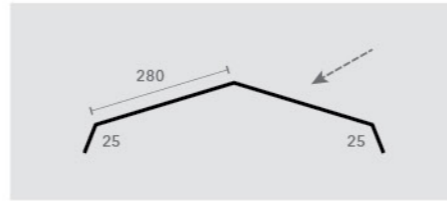

FLASHING A SC12

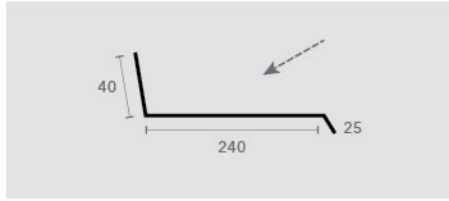

FLASHING A SC18

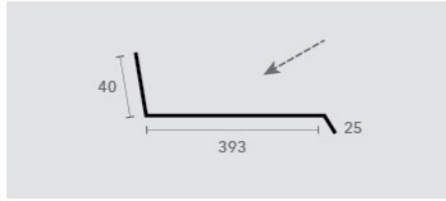

FLASHING A SC24

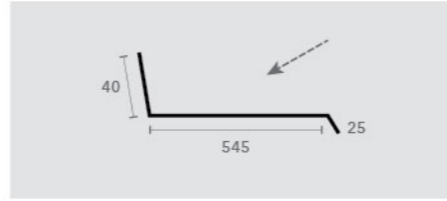

FLASHING B SC12

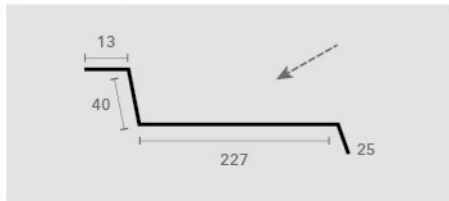

FLASHING B SC18

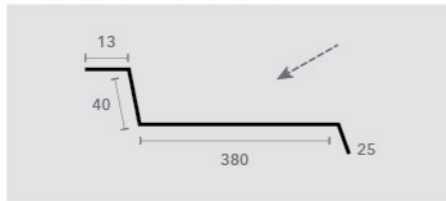

FLASHING B SC24

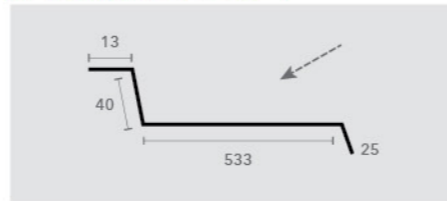

FLASHING C SC12

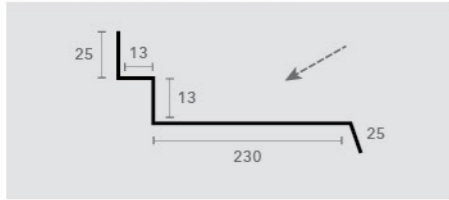

FLASHING C SC18

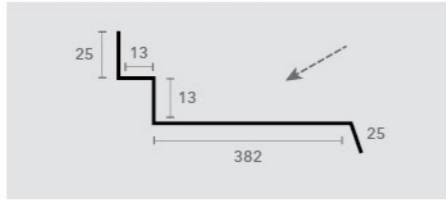

FLASHING C SC24

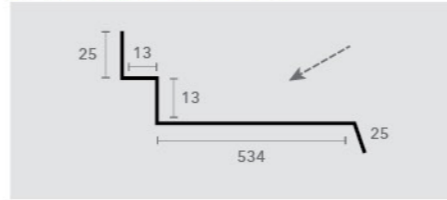

FASCIA SC9

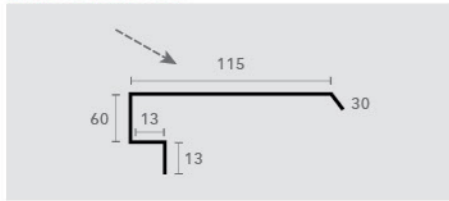

FASCIA SC18

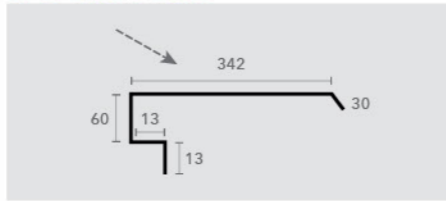

FASCIA SC24

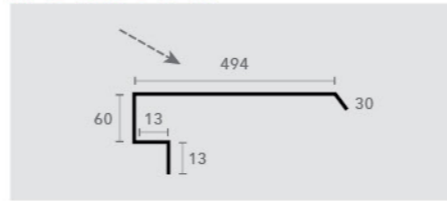

FASCIA 3' SC6

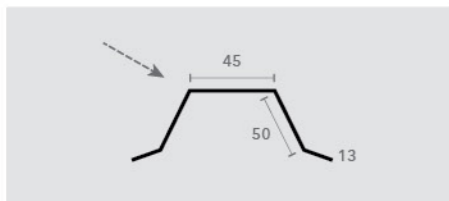

VALLEY SC18

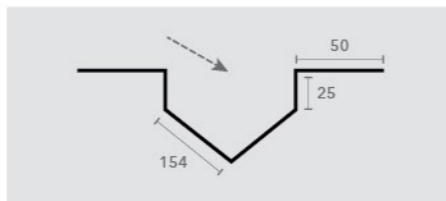

VALLEY SC24

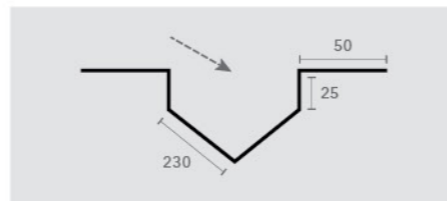

(ALL UNITS ARE MEASURED IN MM)

TRUST US WITH CSC



SENGDEK roofing are supplied by top quality local steel coil manufacturer, CSC. CSC was established and listed on the main market of Bursa Malaysia. It is the largest steel coil manufacturer in Malaysia. The main products of CSC steel include galvanised steel coils (gi) and pre-painted steel coil (ppgi).

Realzinc and Realcolor are shaped under CSC, providing the best quality of steel coil to create infinite possibilities.

The concept of "real" is originated from value of reality and practicality which closely aligned with CSC upright business philosophy, besides communicating the company's management ways by "making with real and achieving the real". It also highlights the company's ambitious in providing steel products that meets the quality standard.

RETAIL SEGMENT



PROJECT SEGMENT

